



Packaging

Features and Highlights



- *Bring order to manual packaging processes*
- *Heavy duty structures*
- *Versatile configurations*
- *Ergonomic design*

Packaging Accessory Stations (PAS)

These units are designed for placement adjacent to existing workbenches and conveyors, or wherever additional storage in the work area is needed.

Packaging Stations (PS)

Start with IAC's rock-solid four-leg workbench, then select from a wide range of utility accessories to ease and speed the tasks in your shipping facility.

Packaging Equipment

Equipment



Roll Storage Stands

Organize those rolled materials with IAC Roll Storage Stands. Both the floor standing and tabletop models hold rolls up to 42 inches wide.

Carton Racks

Built from heavy-gauge steel and finished with a durable powder coat paint, these racks are built to last. Tube steel dividers are removable and positionable in 6" increments.



1 Product Selection

1. Select a Packaging Station (PS) or Packaging Accessory Station (PAS) based on your requirements. *Note: The PS begins with a basic bench onto which is added the selected accessories.*
2. Choose a part number based on the length need, and in the case of the PAS, the height as well.
3. For the Packaging Station Bench select a worksurface, and a color if laminate is chosen. Note that Standard and ESD laminates have separate color choices and codes. See laminate color selection on page A-16.
4. Choose accessories to be included on selected PS or PAS. The accessory section is divided between PS-only accessories and PS/PAS accessories.
5. Choose a Basic Paint color. This color, in addition to the main Packaging Station structure, will be used on any painted accessories selected with original order. See paint color selection on page A-15.
With these items selected you are ready to write up the order.

These two pages will guide you in configuring and structuring your order or quote request for IAC Packaging Stations and Packaging Accessory Stations. The professional staff at IAC is ready to assist you in building the Packaging Station that best fits your needs and application. To prevent errors and to speed order fulfillment, IAC recommends that you follow the steps outlined here when selecting, ordering and receiving products.

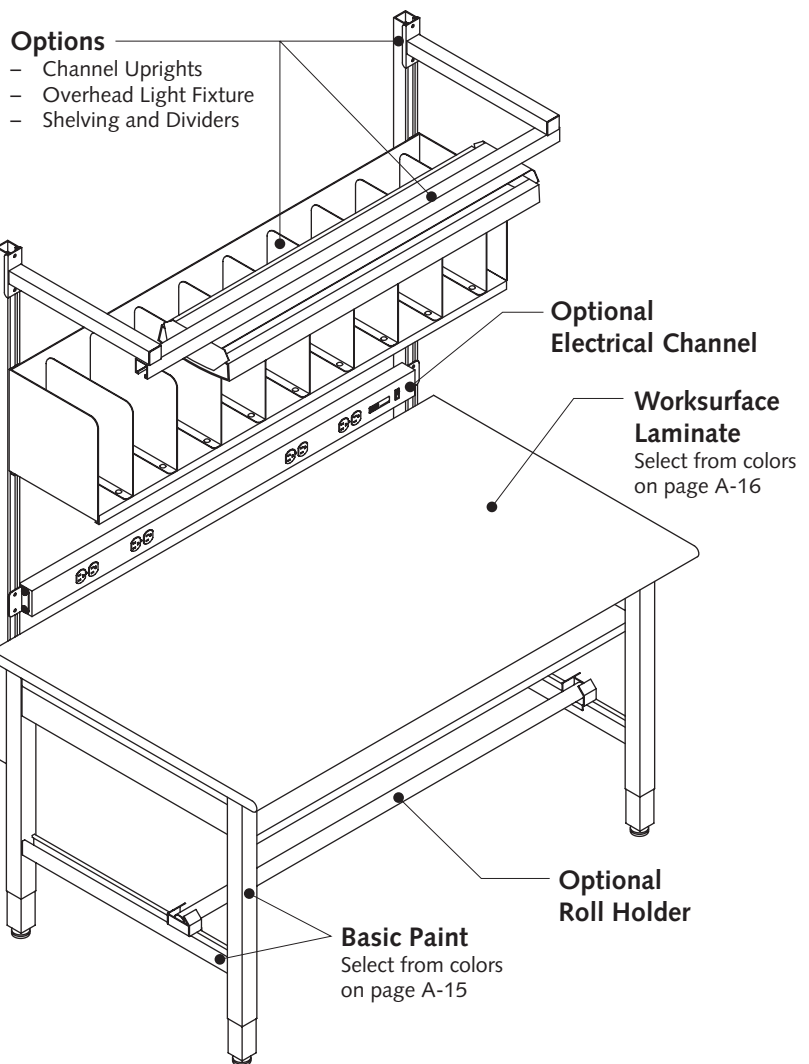



2 Product Orders

1. Packaging Equipment products are delivered Knocked Down (KD) unless otherwise specified. Please refer to Terms and Conditions, page A-13, for additional assembly charges, and to page A-12 for Delivery Considerations.
2. Product Orders should be written with each Packaging Equipment product and its accessories grouped and fully specified before adding another Packaging Equipment product with different specifications.

Please see example on right.

3 Product Receipt

IAC products are fully inspected before leaving the factory to assure full satisfaction. Should any claims develop that require product return it is important that certain steps be followed. Please review Receiving Shipments on page A-12 before opening shipments from IAC.

Example:

- *Packaging Station Series*
- *Length = 60"*
- *Depth = 36"*

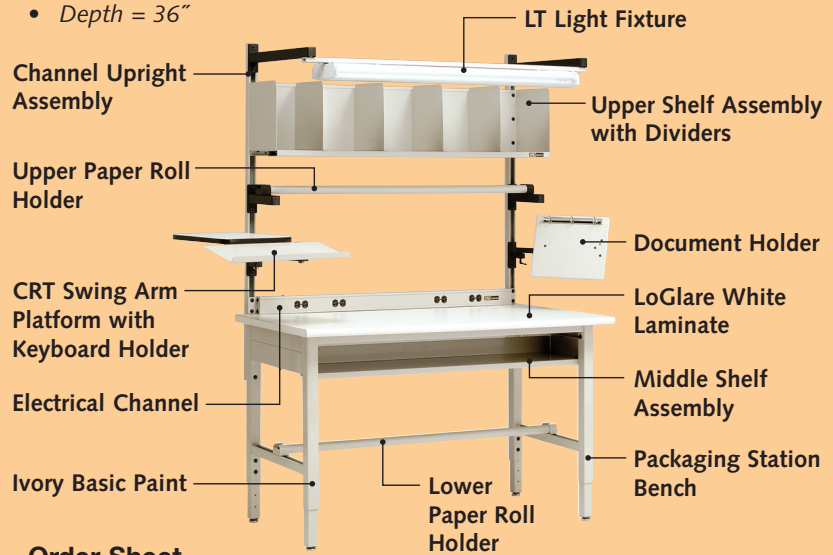

Order Sheet

Line No.	Part Number or Item Code	Description	Quantity
1	KD	Shipped as Kocked Down – Customer Assembled	
2	00230-5003	36" x 60" Packaging Station Bench	5
3	C	Basic Paint Color: Ivory	
4	O1	Worksurface Standard Laminate: Lo Glare White	
5	01620-1660	60" Upper Paper Roll Holder	5
6	01620-1910	CRT Swing Arm – Standard Laminate	3
7	O1	CRT Platform Laminate Color: Lo Glare White	
8	01620-1915	Keyboard Holder	3
9	08713-0001	Channel Upright Assembly	5
10	02241-6000	52" Electrical Channel	2
11	01620-1960	60" LT Light Fixture	5
12	01260-1260	12" x 60" Upper Shelf Assembly	5
13	08402-1212	12" x 12" Upper Shelf Divider	20
14	01620-1904	Clip Portrait Document Holder	2
15	01261-1260	60" Middle Shelf Assembly	5
16	01620-1760	60" Lower Paper Roll Holder	3
		Continue grouping configurations as above for all workbenches in your order. Please call the factory with questions regarding order placement to avoid processing delays.	

IAC PS Series

Pack It Up!

IAC's Packaging Equipment provides shippers with rugged and versatile platforms to efficiently handle the most demanding packing tasks.

- Versatile Configurations
- Heavy Duty Structures
- Ergonomic Designs



- Weight Capacity: 1000 lbs. evenly distributed
- Steel frame finished with powder coat paint
- Industrial-grade, low-glare laminate worksurface with 180° rolled front edge

Dimensions	Standard Laminate	ESD Laminate	Maple Laminate
30"D x 60"L	00230-5001	00230-6001	00230-7001
30"D x 72"L	00230-5002	00230-6002	00230-7002
36"D x 60"L	00230-5003	00230-6003	00230-7003
36"D x 72"L	00230-5004	00230-6004	00230-7004

Packaging Stations — PS Series

Start with IAC's rock-solid four-leg workbench, then select from a wide range of utility accessories to ease and speed the tasks in your shipping facility. Designed for seated or standing users, the telescoping legs provide worksurface height adjustment ranging between 30 to 36 inches in 2-inch increments. The impact- and chemical-resistant worksurface features a 180° rolled front edge for comfortable use. The Channel Upright Assembly attaches to the workbench and supports above-the-worksurface accessories, while additional options provide storage under the bench.

Productivity Accessories

PS and PAS Series offer a wide range of accessories that include shelves, shelf dividers, electrical channels, lighting, and paper/wrap spool holders. Swing arm-mounted document holder, and CRT platform offer ergonomic answers to information input. The open U-shaped Channel Uprights allow infinite positioning of each selected accessory.

Packaging equipment frames, channels and shelving accessories are finished in durable (MD) Soft Gray color powder coat paint that is electro-statically applied and baked to a hard, chip-resistant coating. Other metal parts are finished with texture-black powder coat.

IAC PAS Series



- Weight Capacity: 250 lbs. evenly distributed
- Steel frame finished with powder coat paint
- Sit-down height (SD)
- Stand-up height (SU)

Length	Sit-Down (SD) Height – 72"	Stand-Up (SU) Height – 84"
48"	00230-8201	00230-8211
60"	00230-8202	00230-8212
72"	00230-8203	00230-8213

Packaging Accessory Stations – PAS Series

These units are designed for placement adjacent to existing workbenches and conveyors, or wherever additional storage in the work area is needed. Packaging Accessory Stations are ideal for organizing packaging materials including rolled paper and wraps, tools, labels, books and manuals. PAS Series stations are free standing structures with two channeled uprights, on which a series of material handling accessories are attached with infinite vertical adjustment. A caster leg option turns the stationary PAS into a mobile version that is easily re-located for continuous benefits.

Productivity Accessories



Holding up to 100 lbs., upper shelves can be positioned anywhere along the Channel Upright Assembly. Shelf dividers are available for better organization.



Swing-arm mounted accessories keep essential equipment, CRTs, and tools close at hand, yet out of the way. Several types are offered.



The optional Middle Shelf provides a convenient spot for forms, labels, markers and other small items you want at your fingertips.



Upper and Lower Paper Roll Holders each hold up to 50 lbs., and are ideal for paper, foam or bubble wraps up to 64" when mounted on a 72" Packaging Station.

IAC PS Bench Accessories

48" Channel Upright Assembly



- Constructed from 1-5/8" heavy-duty square channel
- Each vertical attaches to the bench leg with three bolts
- Overall Weight Capacity: 250 lbs. evenly distributed
- Powder coat paint finish

Part Number

08713-0001

Middle Shelf Assembly

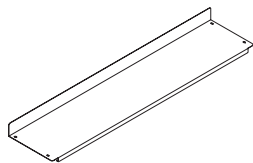

- Mounts directly beneath the worksurface with 6-in. vertical clearance for storage of flat items, supply trays, etc. (not for use on benches where personnel require knee clearance for sitting)
- Includes a 3-in. back panel
- Includes bracket kit to attach shelf to bench legs

Dimensions	Part Number
12"D x 60"L	01261-1260
12"D x 72"L	01261-1272

Lower Shelf Assembly

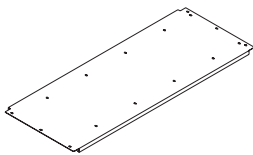

- Mounts to cross-beam supports between bench legs (not for use with Lower Paper Roll Holder)
- Accepts mounting of Shelf Dividers (below) in 6" increments (maximum of 7 dividers for 60" shelf and 9 dividers for 72" shelf)
- Weight Capacity: 75 lbs. evenly distributed

Dimensions	Part Number
22"D x 60"L	01262-2260
22"D x 72"L	01262-2272

Lower Shelf Divider

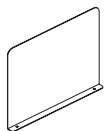

- Mounts to Lower Shelf Assembly (see shelf specifications, above)
- May also be used as shelf end caps
- 13"H x 18"D

Part Number

08402-1318

Lower Paper Roll Holder

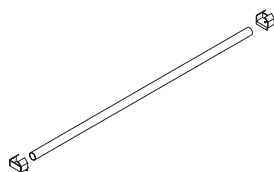

- Mounts to cross-beam supports between bench legs (not for use with Lower Shelf Assembly)
- Accommodates rolls to 27" dia. (depending on worksurface height)
- Weight Capacity: 50 lbs.

Product Length	Roll Length Capacity	Part Number
60"	52" Long	01620-1760
72"	64" Long	01620-1772

IAC PS and PAS Accessories

Common Accessories for Packaging Stations and Packaging Accessory Stations



Packaging Station (PS)

Options Shown:

- Channel Upright Assembly
- LT Light Fixture
- Upper Shelf Assembly
- Upper Shelf Dividers
- Upper Shelf Backsplash
- Upper Paper Roll Holder
- CRT Swing Arm Platform
- Keyboard Holder
- Electrical Channel
- Middle Shelf Assembly
- Lower Paper Roll
- Pictured with 3-Ring Document Holder



Packaging Accessory Station (PAS)

Options Shown:

- LT Light Fixture
- Upper Shelf Assembly
- Upper Shelf Dividers
- Upper Shelf Backsplash
- Upper Paper Roll Holder
- CRT Swing Arm Platform
- Keyboard Holder
- Electrical Channel

Upper Paper Roll Holder

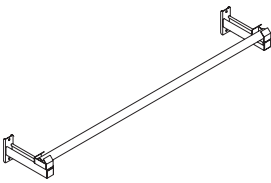

- Adjusts up and down along uprights and in/out from 1" to 9" (from face of upright to center of roll)
- Weight Capacity: 50 lbs.

Product Length	Roll Length Capacity	Part Number
60"	52" Long	01620-1660
72"	64" Long	01620-1672

Electrical Channel

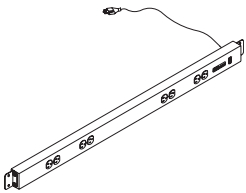

- Four (4) 15-amp, 60-Hz duplexes
- Mounts anywhere along Channel Upright Assembly
- Includes 15-amp circuit breaker and 8-ft. molded power cord

Product Length	Bench Compatibility	Part Number
52"	60" Long	02241-6000
64"	72" Long	02241-7200

LT Light Fixture

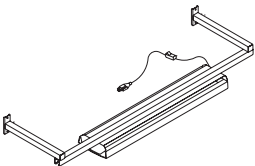

- Two-tube, 48" light mounted to 60" or 72" support structure (tubes not included)
- Includes 8-ft. power cord with switch
- Built to rigid UL and NEC standards

Dimensions	Part Number
60" Long	01620-1960
72" Long	01620-1972

IAC PS and PAS Accessories

Upper Shelf Assembly

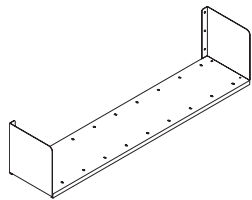

- Mounts to upright assembly with brackets that double as shelf end caps
- Accepts mounting of Shelf Dividers (below) in 6" increments (maximum of 9 dividers for 60" shelf and 11 dividers for 72" shelf)
- Weight Capacity: 100 lbs. evenly distributed
- Powder coat paint finish

Dimensions	Part Number
12"D x 60"L	01260-1260
12"D x 72"L	01260-1272
18"D x 60"L	01260-1860
18"D x 72"L	01260-1872

Upper Shelf Divider

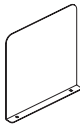

- Mounts to Upper Shelf Assembly for sorting and organizing supplies (see shelf specifications above)
- Powder coat paint finish

Dimensions	Part Number
12"W x 12"H	08402-1212
12"W x 18"H	08402-1218

Upper Shelf Backsplash

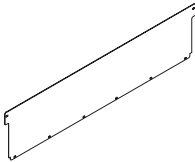

- Mounts to back of Upper Shelf Assembly to prevent supplies from falling off shelf's back
- Powder coat paint finish

Dimensions	Part Number
12"H x 60"L	01263-3060
12"H x 72"L	01263-3072

Swing Arm Tool Caddy

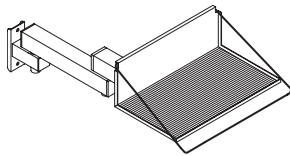

- Provides platform for accessible storage
- Rotates 360° on swing arm
- Removable ribbed rubber mat lining
- Platform has rubber feet for worksurface protection
- Can be used with or without swing arm
- Swing Arm is painted Textured Black. The Tool Caddy is painted to match the bench frame, unless otherwise specified.

Part Number
01620-1920

4" Caster Kit

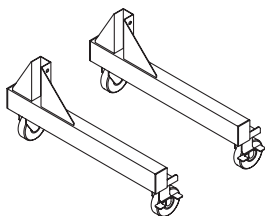

- Turns a Stationary Accessory Station into a "Mobile" Accessory Station
- Set of four 4" plate-mount casters
- Wheel locks on two casters
- Roll Storage Stand legs are pre-drilled for caster mounting (floor standing model only)
- Adds 5 inches to height of Packaging Accessory Station

Description	Part Number
Retro-fit	00230-8298
Upgrade	00230-8299



Flat Panel Display Swing Arm

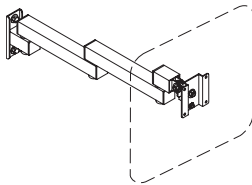

- Provides positioning in two planes for optimum viewing angles
- Universal display mount

Part Number

01620-1916

CRT Swing Arm Platform

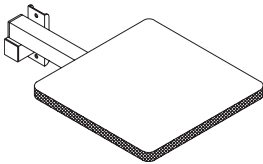

- Platform rotation allows wide range of monitor locations
- Weight Capacity: 25 lbs.
- Edged in Black T-mold

Laminate

Standard
ESD

Part Number

01620-1910
01620-1912

G
10

Keyboard Holder

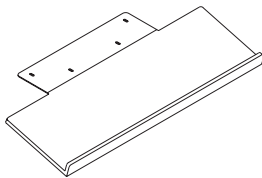

- Mounts to CRT Swing Arm Platform
- Accommodates most extended keyboards and mouse

Part Number

01620-1915

Clip Portrait Document Holder

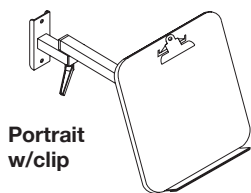

Portrait
w/clip

- Swing arm pivots at bracket and at pan for maximum position options; can be positioned anywhere up and down the uprights
- Clip and bottom lip hold documents in place



Landscape
w/3-ring

Description	Portrait	Landscape
w/clip	01620-1904	01620-1903
w/3-ring	01620-1902	01620-1901

Packaging

Equipment



Organize those rolled materials with IAC Roll Storage Stands. Both the floor standing and tabletop models hold rolls 8" shorter than the spindle length. Use for foam or bubble wrap, wrapping paper, plastic sheeting, mailing and shipping labels. Make the floor model mobile with the addition of the 4-inch caster retrofit option.



3-roll, floor stand model



Single roll, tabletop model

Floor Standing Roll Stand – 3 Spindles

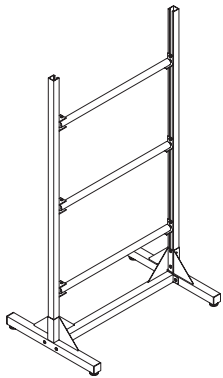

Holds rolls 8" shorter than spindle length

- Constructed from 1-5/8" heavy-duty uni-strut square channels
- Load Capacity: 300 lbs. total; 100 lbs. per spindle
- Powder coat paint finish

Dimensions	Part Number
38"W x 72"H	00230-8301
50"W x 72"H	00230-8302
62"W x 72"H	00230-8303

4" Plate Caster Kit (for floor standing model)

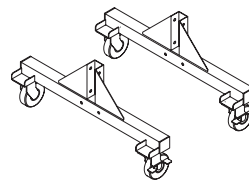

Adds 5" to height

- Set of four 4" plate-mount casters
- Wheel locks on two casters
- Roll Storage Stand legs are pre-drilled for caster mounting (floor standing model only)

Description	Part Number
Retro-fit	00230-8398
Upgrade	00230-8399

Tabletop Roll Stand – 1 Spindle

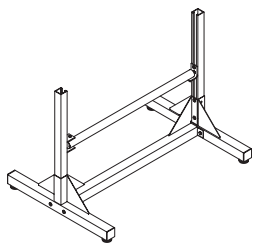

Holds rolls 8" shorter than spindle length

- Constructed from 1-5/8" heavy-duty uni-strut square channels
- Load Capacity: 100 lbs.
- Powder coat paint

Dimensions	Part Number
38"W x 30"H	00230-8311
50"W x 30"H	00230-8312
62"W x 30"H	00230-8313

Spindle

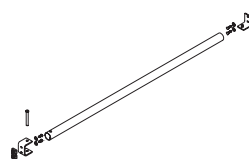

Holds rolls 8" shorter than spindle length

- Fits both Floor and Tabletop Roll Stands
- Load Capacity: 100 lbs.

Dimensions	Part Number
38"L	01620-1638
50"L	01620-1650
62"L	01620-1662

G
11

Packaging
Equipment

Carton Racks



Keep cartons and other packaging materials handy and organized with Carton Racks from IAC. Built from heavy-gauge steel and finished with a durable powder coat paint, these racks are built to last. Tube steel dividers are removable and positionable in 6" increments.



2-Tier 8 Dividers

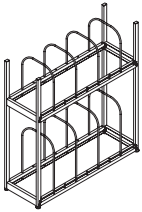

- Square steel channel construction
- Includes 8 removable steel hoop dividers
- 9 dividers per tier maximum; 6" spacing
- Weight Capacity: 350 lbs.
(250 lbs. with 3" casters option)

Dimensions	Part Number
18"D x 44"L x 60"H	00230-8001
18"D x 54"L x 60"H	00230-8002
24"D x 44"L x 60"H	00230-8011
24"D x 54"L x 60"H	00230-8012

1-Tier 5 Dividers

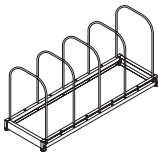

- Square steel channel construction
- Includes 5 removable steel hoop dividers
- 9 dividers maximum; 6" spacing
- Weight Capacity: 350 lbs.
(250 lbs. with 3-inch casters option)

Dimensions	Part Number
18"D x 44"L	00230-8101
18"D x 54"L	00230-8102
24"D x 44"L	00230-8111
24"D x 54"L	00230-8112

Shelf Pan

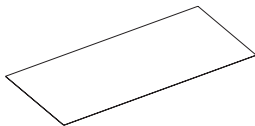

- Fits into base frame to prevent small boxes or envelopes from falling through
- Sheet steel with cleats on bottom to maintain position

Dimensions	Part Number
18"D x 44"L	01262-1844
18"D x 54"L	01262-1854
24"D x 44"L	01262-2444
24"D x 54"L	01262-2454

Caster Set

- Set of four casters
- Wheel locks on two casters
- Suitable for a 1- or 2-tier rack
- Applicable to Carton Racks only

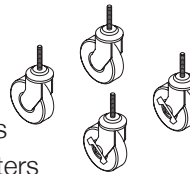

Description	Part Number
3" Caster Set	00230-8199
4" Caster Set	00230-8198

Dividers

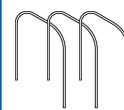

- Each rack accepts up to 9 dividers; 6" spacing

Dimensions	Part Number
18"D x 24"H	08402-1824
24"D x 24"H	08402-2424